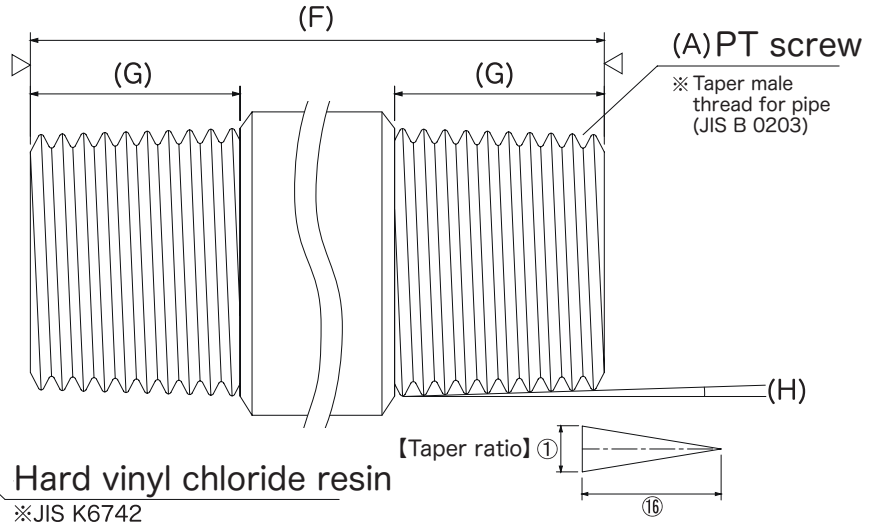
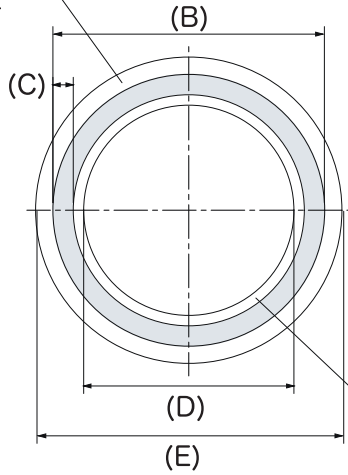
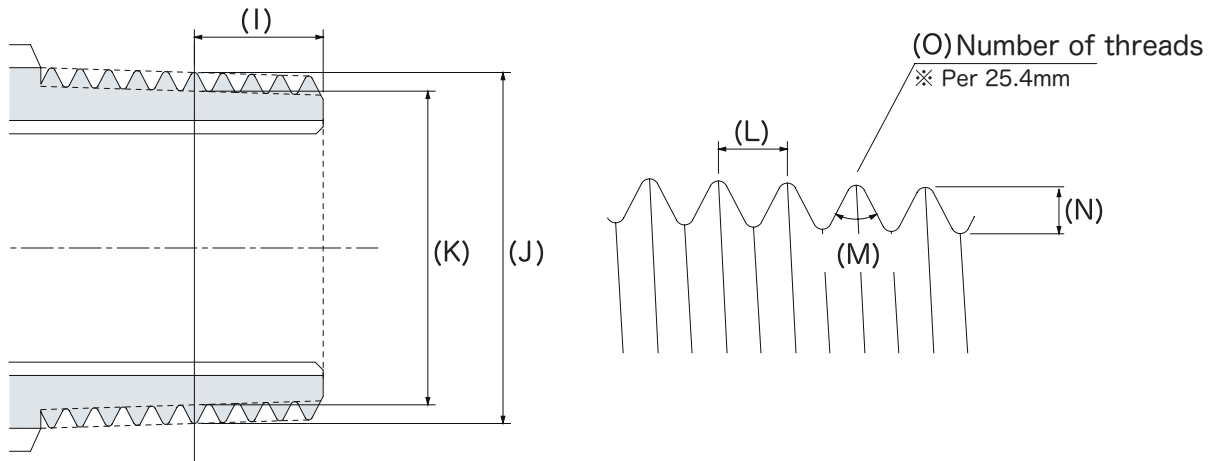

Hard vinyl chloride resin

※JIS K6742

【Detailed view of screw】

※ Dimensional unit is mm

A	Size	15A	20A	25A	32A	40A	50A	65A	80A	100A
B	Outer diameter(Φ)	21.7	27.2	34.0	42.7	48.6	60.5	76.3	89.1	114.3
C	Thickness(t)	2.8	2.8	3.2	3.5	3.5	3.8	4.2	4.2	4.5
D	Inner diameter	13.1	18.6	24.6	32.7	38.6	49.9	64.9	76.7	101.3
E	Coating Outer diameter	25.7	31.0	37.8	46.3	52.0	63.7	79.5	92.3	118.3
F	Short nipple dimensions									
G	Screw dimensions	16.5	18.5	20.5	24.5	24.5	28.5	34.5	38.5	44.5
H	Taper angle	1.7899°	1.7899°	1.7899°	1.7899°	1.7899°	1.7899°	1.7899°	1.7899°	1.7899°
I	Effective thread size	8.16	9.53	10.39	12.7	12.7	15.88	17.46	20.64	25.4
J	Effective diameter(Φ)	20.955	26.441	33.249	41.91	47.803	59.614	75.184	87.884	113.03
K	Effective valley diameter(Φ)	18.631	24.117	30.291	38.952	44.845	56.656	72.226	84.926	110.072
L	Screw pitch	1.8143	1.8143	2.3091	2.3091	2.3091	2.3091	2.3091	2.3091	2.3091
M	Thread angle	55°	55°	55°	55°	55°	55°	55°	55°	55°
N	Thread height	1.162	1.162	1.479	1.479	1.479	1.479	1.479	1.479	1.479
O	Number of threads	14	14	11	11	11	11	11	11	11